



Modular Air-cooled Chiller (Heat Pump)

EKAC Series

Environmentally-Friendly Refrigerant-Type
Modular Air-Cooled Heat Pump Chiller

Standard: EKAC230BR1/EKAC460B(R)1

Total heat recovery type: EKAC230BR1SR/EKAC460BR1SR

Four-pipe heat recovery: EKAC460BR1SRF

Refrigerant: R410A





EUROKLIMAT

Origin of EK — Guangdong Euroklimat Air-Conditioning & Refrigeration Co., Ltd. ("EUROKLIMAT" for short) was founded in 2009. Till now, EUROKLIMAT products are sold in many countries and regions such as China, India, Thailand, Indonesia, Myanmar, South Africa, United Arab Emirates, Chile, and Bangladesh. Driven by technical innovations and taking energy conservation-oriented approaches, EUROKLIMAT is committed to developing into a world-leading environmental system integrator and service provider. The six main air conditioning products of EUROKLIMAT are fluorine system products, water system products, air handling units, units for data centers, high-efficiency equipment rooms, and smart homes. Besides, EUROKLIMAT boasts core competencies in heat recovery, condenser and evaporator capacity, and precision control.

Development of EK — After years of development and endless exploration, now EUROKLIMAT has 1,200 employees in China working in many departments involving marketing, R&D, manufacturing, and after-sales services. EUROKLIMAT has over 10 testing laboratories accredited by CNAS, a technology R&D center in the Asia Pacific region, and the over-100,000m² EK industrial park. All products are manufactured through world-leading air conditioning technologies and processes. We have provided high-efficiency and energy-saving central air conditioners with an estimated value of RMB10 billion to the Chinese market. In the era of 5G, EUROKLIMAT keeps pace with development. We have established the EK-CLOUD platform that supports real-time monitoring of devices, to provide users with comprehensive industry solutions.

Honors of EK — National High-tech Enterprise, Testing Laboratory Accredited by CNAS, Chinese Standard Innovation Contribution, Enterprise of National Major Energy-Saving Electronic Products, Guangdong Energy-Saving and Environmental-Protection Air Conditioning Engineering Research Center, IPR Superior Enterprise in Guangdong, Guangdong Enterprise Technical Center, Guangdong Enterprise with AAAA-Standardized Conduct, Guangdong Famous Enterprise, Guangdong Enterprise with High Reputation, Informatization and Industrialization Integration Management System Accreditation, and IPR Management System Accreditation. EUROKLIMAT led and participated in the preparation of a series of national standards such as GB/T25857-2010 Low Ambient Temperature Air Source Multi-connected Heat Pump (Air Conditioning) Unit, GB/T 18837-2015 Multi-connected Air-condition (Heat Pump) Unit, GB/T 33656-2017 Thermal Comfort Requirements and Evaluation for Indoor Environment, and JB-T 13515-2018 Positive Displacement Water-Chilling (Heat Pump) Packages with Full Heat Recovery.

Message from EK — For EUROKLIMAT, energy efficiency is the relentless pursuit, and comfort and natural life is the eternal goal. Under the concept of "Give life to building & bring us back to nature", and adhering to the commitment of energy conservation and environmental protection, EK, to achieve harmony with nature, will keep developing comfortable and energy-saving air conditioners and join hands with partners to create a bright future.



2020

Total sales of commercial air-cooled heat pumps exceeded 50,000 sets

2016

Launched -30°C ultra-low-temperature heat pump coal-to-electricity commercial units

2015

Led drafting of standards for total heat recovery industry

2011

The first manufacturer who launched the low-temperature high-efficiency total heat recovery heat pump unit

2008

Introduced European air-cooled heat pump technology and total heat recovery technology to China

2004

Started to supply ultra-low temperature air source heat pumps in the European market

2003

Launched air-cooled all heat recovery units in the European market

1975

Designed air-cooled special precision air conditioners

1965

Designed condensing heat recovery units

1964

Designed and manufactured air-cooled heat pump units

1963

Founded in Milan, Italy

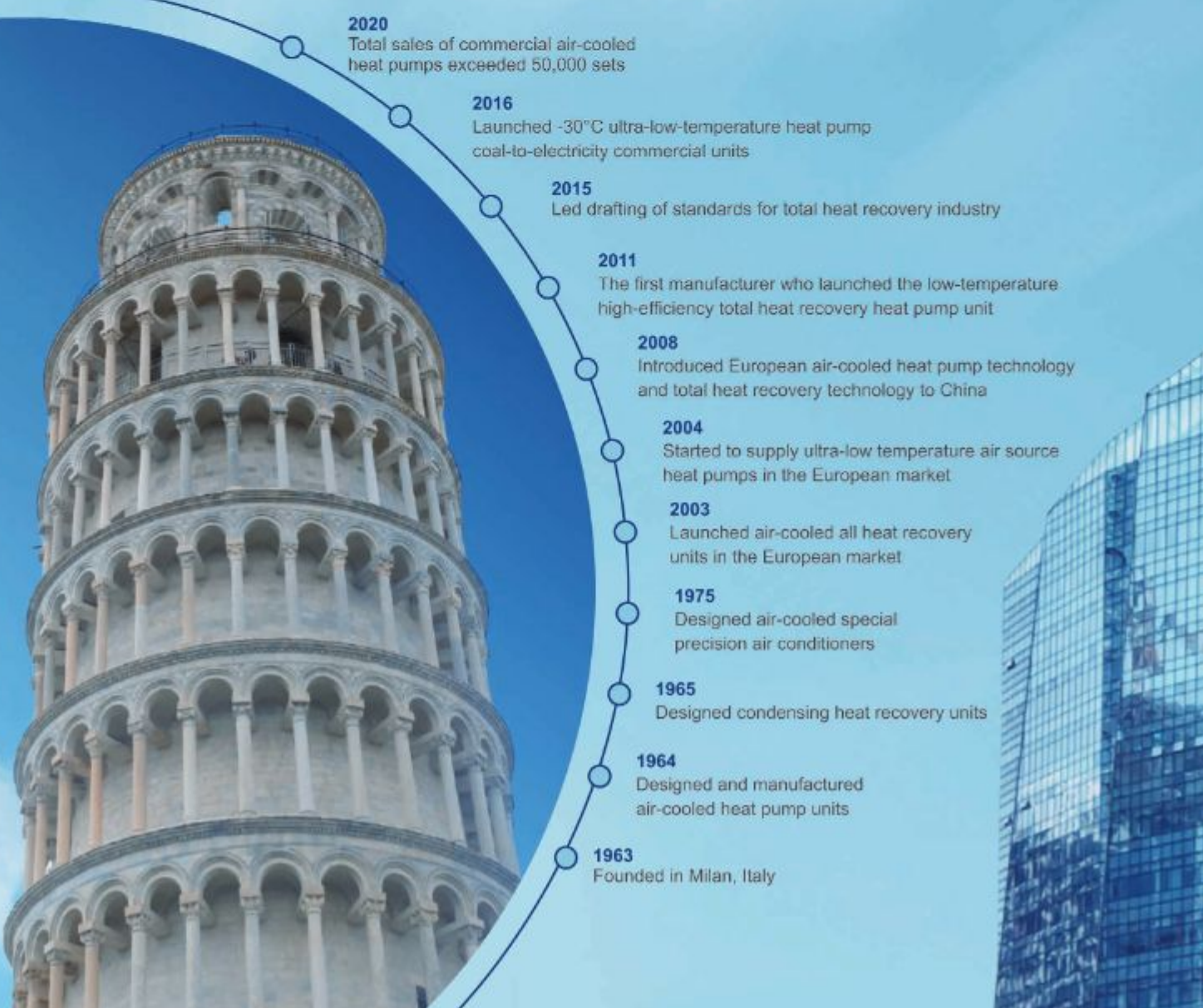



Contents

● 59 Years of Heat Pump Technologies	03
● Energy-saving and Environmentally-friendly, Fully Enjoying Green Technology	04
● Excellent Control, Delivering Excellent Performance---	05
● Core Components, Experiencing Original Masterpiece--	07
● Stable and Reliable, Guaranteeing Safe Use	09
● Optimized Details, Showing Lean Quality	11
● AI Defrosting, Innovative Smart Technology	12
● Intelligent Control, Convenient O&M Management---	13
● IoT+, Creating Extraordinary Experience	15
● Standard Air-cooled Modular Unit	17
● One Unit for Multiple Purposes, Five Operation Modes---	19
● Four-pipe Modular Unit	22
● Unit Capacity Change Table	25
● Unit Dimensions	27

59 Years of Heat Pump Technologies

59

EK modular air-cooled heat pump units combine the essence of Euroklimat accumulated over 50-year air-cooled heat pump design experience with the demand in the modular unit market of China, to fully satisfy customers' requirements on efficiency, environmental friendliness, comfort, safety, and smartness to the greatest extent. Available in a wide range of models, these units are applicable to new or rebuilt industrial and civil buildings in all sizes, such as hotels, restaurants, recreational centers, hospitals, dining halls, offices, cinemas, factories, and supermarkets, especially to those rising high requirement on noise reduction and ambient environment and where water is lacking or cooling water tanks are inapplicable. Featuring flexibility in installation, quickness in construction, and simplicity in pipelining, these units allow phase-based and moderate investment and have no requirement on the chilled water system, therefore becoming one of the best choices for users.



Nomenclature

EKAC **230** **B** **R** **1** **SR-F** **AA**
 1 2 3 4 5 6 7 8

- 1 EKAC EK Modular Air-cooled Chilling Water (Heat Pump) Unit
- 2 230 Cooling capacity code
- 3 B Design No.
- 4 R Functional type R: cooling and heating type; cooling type (default)
- 5 1 Refrigerant code: 1: R410A;
- 6 SR Product special feature: standard (default)
 LH: Low-temperature heating standard type;
 SR: Total heat recovery standard type;
 LH: Low-temperature heating standard type;
 LC: Total heat recovery standard type;
- 7 F Power feature: F: 380V/3N~50Hz
- 8 AA Specific description of product specification changes



Participation in drafting national/industry standards



EK modular units have 29 patents (including 3 national invention patents). The hybrid connection air-cooled chiller has obtained a PCT international patent certificate.



Application scenarios



Energy-saving and Environmentally-Friendly

Fully enjoy green technology



Environmentally-friendly in response to EU RoHS Directive

EKAC series unit adopts environmentally friendly galvanized sheets certified by EU RoHS. The EU RoHS Directive stipulates that the following six hazardous substances (lead, mercury, cadmium, hexavalent chromium, polybrominated diphenyl ether (PBDE) or polybrominated biphenyl (PBB)) are prohibited to be used in electrical and electronic equipment. EK strictly controls the use of hazardous substances in the manufacturing process, aiming to protect the health of the users and ensure that the recycling and disposal of scrap electronic and electrical equipment meet environmental requirements.



Energy conservation and emission reduction

EKAC series adopts the efficient and environmentally friendly R410A refrigerant and its ODP is 0, which means the products will not destroy the atmospheric ozone layer. A maximum cooling capacity of unit volume that requires a much smaller refrigerant charge compared to traditional refrigerants could help reduce greenhouse gas emissions.



Energy-saving and environmentally-friendly

EKAC series have passed the Attestation of Chinese environment mark, which means that they not only keep efficient and energy-saving but also allow you to enjoy a green and environmentally-friendly air-conditioning environment.



Attestation of Chinese environment mark



Product certificate of Attestation of Chinese environment mark



High energy efficiency

Innovating the European leading air-cooled heat pump design concept, the whole series of products meet the second-level energy efficiency standard (COP higher than 3.2), energy efficiency ratio at full load is up to 3.45, exceeding the national first-level energy efficiency standard (COP higher than 3.4).



EER at full load up to 3.45



More energy efficient under partial load

Each unitary module is equipped with 2-level energy adjustment. You can turn on only one system under partial load. When multiple units are combined, multi-level energy adjustment is available. Comprehensively-improved system selection and match ensures that the unit is kept in the optimal energy-saving state. In the partial load mode (about 99% of the total operation time of the air conditioner), the output of the unit is intelligently adjusted according to the actual load. The operation efficiency of the unit is higher and the efficiency is increased by 4%.

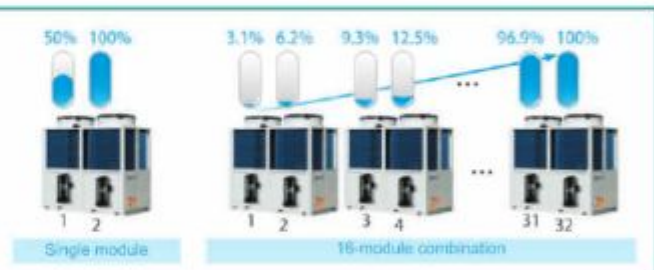

Energy-saving mode

Energy saving mode can be set to reduce energy consumption according to the time period of people flow in the place!



Pump energy-saving mode (optional)

Taking advantage of the thermal insulation and cold/thermal inertia of the buildings, the energy-saving mode of the water pump can be selected at this time to reduce consumption of the water pump while maintaining the basic heat required by the buildings.

Excellent Control Delivering Excellent Performance



First "hybrid connection technology" in the industry

EK is the first manufacturer to launch the hybrid connection technology that combines the total heat recovery modular air-cooled heat pump unit with the standard modular air-cooled heat pump unit. The total heat recovery unit can be combined with the standard modular unit to form a unit with partial heat recovery function. It can also be combined with the total heat recovery unit to form a unit with total heat recovery function to address different needs of customers for heat recovery amount. Such hybrid connection technology has passed invention patent certification and obtained a PCT international patent certificate. At the same time, the hybrid connection control can also be applied to modular units with different cooling/heating capacity to meet the customer's different demand.



Patent No.: ZL 2010 1 0202580.4

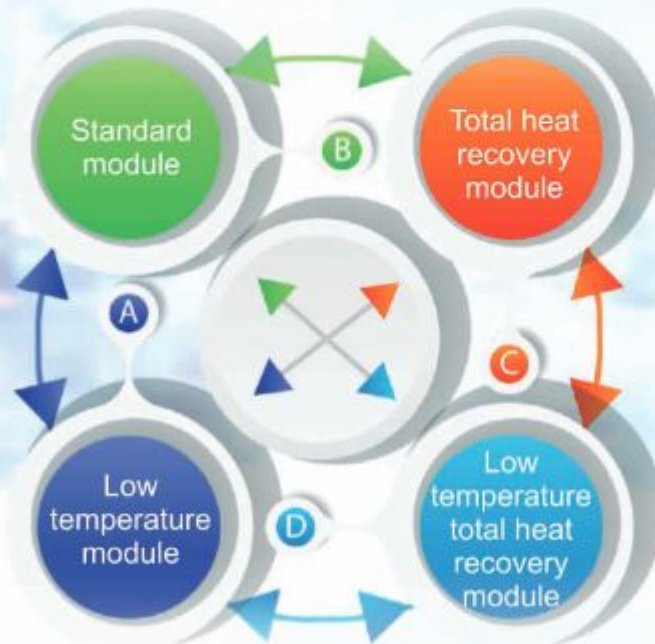

Hybrid connection advantages

- Under partial load, more energy is saved. At 99% time, the unit runs under partial load. In cooling + heat recovery mode, the unit can preferentially start the heat recovery unit, thus saving more energy during operation.
- In winter, heating + hot water mode can run at the same time. In the case of hybrid connection, the unit can both provide heating and domestic hot water functions, and therefore, the system is more intelligent.
- The unit can average the compressor wear time of all the units in a complete set of the control system. The average service life of the system is prolonged, thus avoiding long operation time of the conventional heat recovery unit and short service life.
- With investment in a set of water system saved, the unit features more intelligent management.



High compatibility

Master/slave integration:

Any slave module can be used interchangeably as a master module. A damaged master module will not affect the use of other modules. Modules of the same or different models can be connected at will. Each system supports up to 16 modules. In contrast, conventional air conditioners use a fixed unit as the master module of the system; when the master module fails, the entire system fails to work, and the maintenance and commissioning are not convenient.



If a running master module fails, the other unit switches to be the new master module.

Dual standby operation:

A single unit adopts multi-compressor design. When a compressor is faulty, the other compressor in the system can still work normally. In the case of a multi-unit system, maintenance or repair of one unit does not affect the operation of the remaining units.



Hierarchical start of modules:

The unit supports a hierarchical start. This can reduce the unit startup current, reduce the impact on the mains grid, and does not affect the safety of electrical devices in the same area.



Hierarchical start: Hierarchical start of modules can reduce the impact of unit startup current on the mains grid.

Modular balance:

The unit monitors the running status of each compressor in real time, and intelligently balances the running time of each compressor, to prolong the service life of the unit.



Refrigerant control technology

Refrigerant pressure detection technology:

The refrigerant pressure detection technology can accurately detect the refrigerant status of the system, and feed back the change of the pressure in real time to the unit control system to timely adjust the operating status, ensuring efficient and safe unit operation.

New Venturi separator:

The Venturi separator with the highest processing precision in the industry is used to ensure the uniform refrigerant flow, reduce pressure loss and noise, and improve heat exchange efficiency effectively.

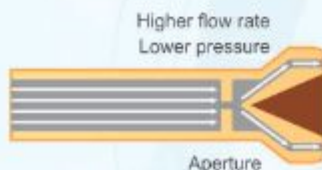

Sectional view



Front view

Multiple electronic expansion valves with accurate temperature control:

The unit is equipped with multiple electronic expansion valves in a single system, which can accurately adjust the refrigerant according to the internal load of the refrigerant system and effectively improve the heat exchange efficiency.



Core Components Experiencing Original Masterpiece



High-efficiency scroll compressor

Adopt international well-known high-efficiency scroll compressor which adopts international leading technologies, and radial flexible and axial flexible scroll compression technology, and add compressor crankcase heater design to prevent high starting resistance of the compressor due to excessive viscosity of lubricating oil. Multiple safe overload protections ensure stable, efficient and reliable operation.

Efficient heat exchanger

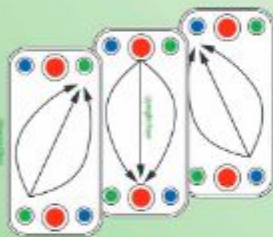

Water-side heat exchanger

The dual-system vacuum brazed plate heat exchanger is made of stainless steel. It adopts the dual-system diagonal-flow design to substantially increase the effective heat exchange area, and boasts higher heat exchange efficiency than shell-and-tube heat exchangers. The dual-system design can automatically adjust the heat balance to guarantee high efficiency and reduce the risk of freezing. The water-side 1.6 Mpa pressure bearing can adapt to the requirements for water systems in ultra-high buildings. The standard water differential pressure switch monitors the unit water flow in real time and provides precise anti-freezing control.

Air-side heat exchanger

360° encircling structure ensures air intaking from all directions. The air resistance is small and the air flow is large, facilitating heat exchange. With the separate air duct, two systems inside the unit can operate independently from each other. This can reduce the fan power consumption under partial load and contribute to better performance. The main materials of heat exchanger are corrugated hydrophilic aluminum anti-corrosion fins and high-efficiency high-tooth internally threaded copper tubes. The hydrophilic aluminum anti-corrosion foils feature low resistance, high efficiency, and long life, which can slow down the corrosion of the corrosion gas on the fins. The heat exchange area of the spiral internally threaded copper tube is larger than that of the bare tube, so that the heat exchange efficiency is improved. The EKAC460/500 units are available with an optional metal protective grille.

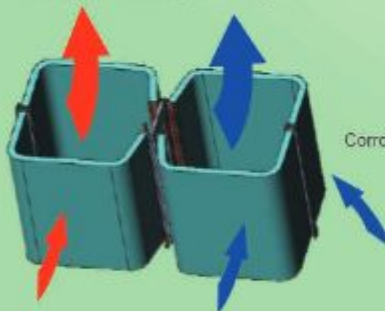

360° encircling heat exchanger

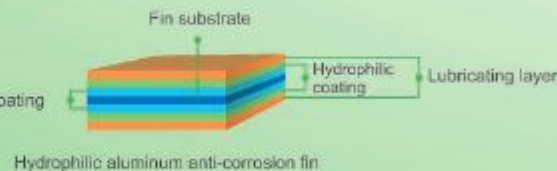

High-efficiency internally threaded copper tube

Electronic expansion valve with accurate temperature control

The EK air-cooled modular unit adopts the quality grade-500 PMV electronic pulse for precise adjustment, to realize the precise PID control of electronic expansion valve, real-time dynamic matching, and higher precision of water temperature control.

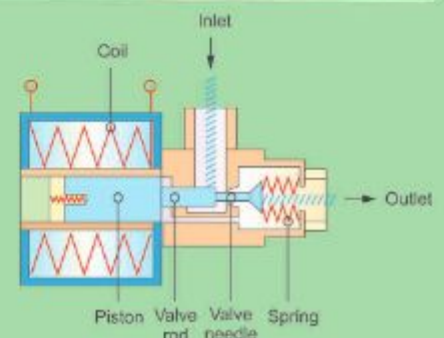

Wing-type spiral fan

Adopt high-efficiency and low-noise airfoil axial flow fan made of aluminum alloy. The dual fans are symmetrical, and the inclination angle and edge design are optimized to effectively control air turbulence and reduce air vortex generation. Two-speed high-efficiency low-noise motor realizes silent operation. With the fan metal mesh enclosure and IP55-rated motor, it can be used in severe weathers such as strong winds and heavy rains, ensuring that the unit can still operate safely and reliably in extreme weather.



Electric control parts

The internal components of the unit are internationally renowned brands. The circuit board adopts SMT sealing technology.

SMT sealing technology,
moisture-proof and anti-interference

Surface Mounted Technology (SMT) means coating sealing material on the surface of the entire main board to improve the anti-clutter performance of main board and protect it from being affected by high temperature, humidity, sand blown by wind and other severe weathers and air environments.



Optimum design of
electric control box

Encased in a double-layered sheet metal structure. Strong and weak currents are separated to avoid mutual interference. Featuring designed trunking, reasonable and beautiful routing, and high safety. The safety design can protect the unit when the current is too high. Current transformer adopts upgraded configuration, which is more timely than traditional overload protection. Double door design is applied for easy maintenance. Upper and lower convection ventilation design enhances the heat dissipation of the electric control box. Waterproof electric control box design delivers higher safety.

Stable and Reliable Guaranteeing Safe Use



Reliable performance

The EK test center has been approved by the China National Accreditation Service for Conformity Assessment (CNAS). By national-level reliability test (with respect to corrosion, fatigue, frequent startup/stop, etc.), the modular unit is highly reliable.



CNAS L5123



Fully automatic inspection

Fully automatic inspection is a new leap between "Internet +" and "intelligence". It performs full inspection and judgment on product components and operating parameters, and automatically completes data collection, data processing, switching among operating conditions, and test result output. The computer and microprocessor are used as the controller to track the product through fully automatic detection, which features high speed, multi-function and multi-parameter, so as to improve the detection efficiency and ensure the stability of the product quality.



Water system operation guarantee

The unit is equipped with a differential pressure switch and a Y-shape filter before delivery so that the unit will not operate in the case of a water shortage, cutoff, or dirty or blocked water system, to ensure reliable unit operation.



Powerful protection function

The unit has 13 built-in powerful protection functions to achieve all-round protection.

Compressor high- and low-pressure protection

Power supply default phase and anti-phase protection

Frequent start protection

Compressor overcurrent protection

Compressor discharge temperature protection

Refrigerant leakage protection

Unit overheat protection

Sensor failure protection

Cooling anti-freezing protection

Winter water system anti-freezing protection

Water flow insufficiency protection

Ambient temperature protection



Multiple prevention measures to ensure quality

Manufacturing preventive measures: The maximum water seal test pressure of the heat exchanger is 4.8 MPa.



Operation guarantee measures



Standard gas-liquid separator and liquid accumulator

The unit could reasonably distribute refrigerant for cooling and for heating, reduce liquid hammer risks, and ensure safety.



Weatherproof function

The unit will not be covered by heavy snow when it is idle in winter.



Ultra wide operating range and adaptable

After being tested strictly according to European standard, the unit has been proved to work normally at as high as 48°C or as low as -15°C. It can be used in schools, hotels, hospitals, industrial plants and other application scenarios.



Flexible application

Flexible investment: The investment can be made in batches, and the unit capacity can be expanded at any time to meet the late investment demand of the owner.

Flexible configuration: EKAC series can not only be connected with each model of the same series, but also with low temperature and heat recovery series.

(Contact EK's technical personnel for details on hybrid connection models)

Flexible transportation: The unit is small in size and can be transported through freight elevators and forklifts. No large lifting equipment is required to facilitate on-site transportation and positioning.

Flexible installation position: No special machine room and no cooling water system are required. Install the unit somewhere well-ventilated, such as the floor, roof, balcony, or ventilation equipment layer.

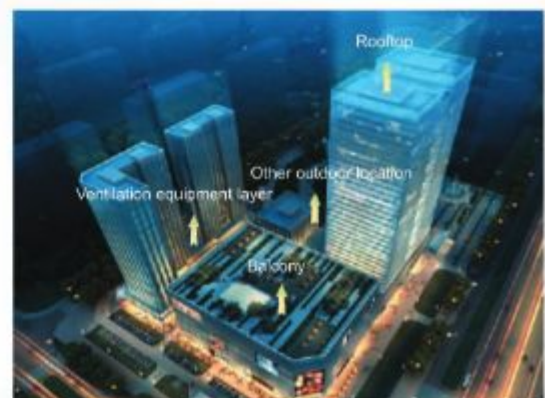

Optimized Details Showing Lean Quality

 The overall vibration isolation, fully hermetic scroll compressor and dual low-speed noise fan are adopted, ensuring industry leading noise reduction grade and anti-vibration degree. Through noise spectrum analysis, it carries out strict comparison, selection and improvement of fans, motors and other components, and performs professional noise reduction on the structure and pipelines.

 Enclosed sheet metal structure at the lower part: For effective shielding of compressor noise.

 An innovative smart silence mode is adopted. The fan speed (high/low gear) can be automatically adjusted based on unit's running state and ambient temperature to allow a unit to work in quiet and low-noise mode. The noise at night is reduced by 6 dB (A).

 Low noise axial flow fan blade design is adopted; a direct drive mechanism is adopted for motor; fan has passed dynamic balance and static balance tests.

Low noise design creating a comfortable environment

User-friendly design

-  The lower enclosure panel of the unit is provided with two buckles for convenient maintenance.
-  The electronic expansion valve and low-pressure sensor adopt a waterproof design to extend the service life of the components.
-  The chassis uses reinforced sheet metal, which is stable and solid.
-  The lower part of the unit body is sealed with sheet metal to protect the components and copper tubes inside.



Centralized drainage

Prevent the bottom condensate flow to the lower parts and cause damages.



AI Defrosting Innovative Smart Technology

AI defrosting technology

Based on the big data platform, the EK units adopt AI technology to develop AI defrosting technology that can adapt to the changes in environmental temperature and humidity.

AI intelligence: multi-dimensional identification and correction

The technology can judge the entry point of defrosting according to the difference between evaporation temperature and outdoor temperature when the heat pump is running and the change rate of temperature difference, evaluate the defrosting quality according to the defrosting time and the temperature parameter of the coil at the end of defrosting, and correct control parameters in real time to obtain the optimized heating effect. Defrosting capability varies depending on the amount of frost, to maximize normal heating time and minimize temperature change caused by defrosting.

AI intelligence: deep optimization and self-learning

The AI intelligent defrosting technology can take into account changes in ambient temperature and humidity, obtain the expression, develop the technology based on the deep network, carry out self-learning through AI intelligence in different regions and under different climate conditions, adapt to the local defrosting mode based on the comprehensive judgment by temperature, refrigerant pressure, and defrosting time, thereby realizing accurate monitoring of intelligent defrosting.

AI intelligence: de-regularization transformation

The unit adapts to various climatic environments. Defrosting conditions will be automatically set with consideration of the defrosting situation of previous periods, which allows the unit, which can only operate mechanically, to realize de-regularization transformation and efficient use of energy.

Staggered defrosting

For a single unit, the two systems are independent of each other. For heating in winters, the two systems realize smart staggered defrosting based on their frosting statuses. When a system is defrosting, the other system is heating. This can prevent substantial water temperature fluctuation during frosting. Also, a single system failure will not affect the use of the other system. In the case of a modular combination of multiple units, the system can intelligently determine when to enter the modular defrosting mode. More than 50% of the compressors in the whole system will enter defrosting mode. This can meet the heating requirements and provide users with a better experience.

Smart staggered defrosting



Narrower water temperature fluctuations



Thermal radiation anti-frosting + condenser design

A unique heat radiation anti-frosting device is equipped in the last refrigerant circuit at the bottom of the heat exchanger. When defrosting, high-temperature refrigerant is introduced into the bottom to effectively prevent the bottom from freezing.

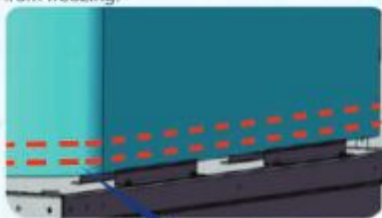

Thermal radiation anti-frosting design

The finned heat exchanger of the EK unit adopts a suspended design, which can prevent the accumulation of rain and snow during the heating process and avoid condensed water freezing at the bottom of the heat exchanger during the defrosting process. The drain pan with high drainage capacity is conducive to the smooth drainage of condensed water during defrosting.



Suspended condenser design

Intelligent Control Convenient O&M Management



Functions

Parameter setting function

- One-key Switch between cooling mode and heating mod
- Time setting
- Timed ON/OFF for one week
- Cooling water inlet/outlet temp.
- Heating water inlet/outlet temp.
- Anti-freezing temperature and defrosting temperature

Memory function

- Memorization function in power outage case
- User's parameters are saved permanently

Defrosting function

- Auto defrosting function
- Manual defrosting function

Parameter display function

- Display of unit operating status
- Set water inlet and outlet temperature, actual water inlet and outlet temperature
- Timed adjustment, anti-freezing temp
- Anti-freezing temp in winter, defrosting temp

Other functions

- Fault diagnosis function
- Historical fault query
- Compressor average wear function and module time-sharing startup function
- Water system two-way valve control function
- Auxiliary electric heating control function
- Remote ON/OFF control function within a maximum of 1,000 meters
- Start/stop control for chilled water pump
- Pump protection feedback
- Terminal two-way valve interlock control

CAN communication

1. Have the advantages of strong real-time property, long transmission distance, and strong anti-interference ability.
2. Adopt two-wire serial communication with strong error detection ability, allowing it to work in an environment with high-noise interference.
3. Information of short frame structure and hardware check realize small probability of interference data error.
4. Reliable error handling and error detection mechanism, and automatic retransmission of information.

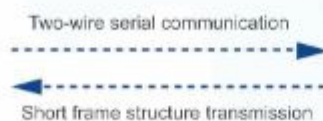

High transmission stability Low transmission error rate High transmission speed

Information error detection Error handling Information retransmission



Microcomputer control system

The unit adopts a microcomputer control system and a large LCD to facilitate operation. A single control system can control up to 16 units and monitor their running state in real time. The optional RS485 COM interface is embedded with the Modbus protocol to realize group control.

Building Automation System (BAS)



RS485



Control and communication

Standard wired touch controller: concise and beautiful LCD touch screen design.

Optional 7-inch touch LCD controller: full touch 7-inch color LCD screen, with more comprehensive parameter display.



IoT+ Creating Extraordinary Experience

5G

EK-CLOUD System Service Provider — Industry pioneer, always walking at the forefront of the times

The "cloud platform" monitoring system service launched for the first time in the industry, making unit maintenance easier (value added service can be selected)

EK is leading the industry in introducing modular air-cooled chillers (heat pump) that can achieve 5G network communication. The EK-CLOUD "cloud platform" can monitor system services, which brings customers more timely and efficient equipment maintenance service, making unit maintenance easier.



Energy consumption analysis



Centralized monitoring



Building automation



Remote monitoring



Early warning and prediction

- The "cloud platform" monitoring system can monitor various devices such as the air-cooled chiller (heat pump), water-cooled chiller, water-source heat pump unit, hot water unit, VRF unit and AHU, realize three-party after-sales service connection of the customer, service organization and EK, bring customers more timely and efficient equipment maintenance service, and provide 24-hour service guarantee.
- Data acquisition: EK can acquire unit operating parameters through the online remote function, upload them to the cloud, self-improve the established cloud platform database after systematic analysis through the cloud server system, and use the parameters as the big data analysis sample of numerous projects.
- Early warning: The cloud system compares the acquired data with the cloud platform database parameters, analyzes the automatic notification service of unit operating status, and overhauls the unit in time in case of any exception to prevent faults and make unit maintenance more convenient.
- Real-time notification: The operating fault alarm can be checked directly through the Web page or sent through a text message or mail to remind the customer, and the diversified alarm notification methods give customers an excellent experience.



EK "cloud platform" control system

Remote maintenance, taking preventive measures

- Simple installation and configuration: Remote equipment management and data interaction operations can be performed without local configuration so long as the network is connected through Ethernet or in (China Mobile/Unicom) 2G/3G/4G/5G mode, etc.
- Long connection distance: The RS485 communication cable can be used for connection and the maximum supported transmission distance is 1000 m. This ensures a flexible installation.
- Many monitoring points: Related operating parameters of all the units involved in a project (regardless of whether there is one or more units in the project) can be collected and uploaded to the cloud server system for effective analysis.
- Wealth of transmitted information: The data collection system collects and uploads data every 2 minutes, and the transmitted information includes all the operating parameters of main unit.



EK cloud platform control system



PC/mobile

Standard Air-cooled Modular Units

Specifications of Combined Unit with a Basic Module of EKAC230BR1 (Partial Parameters)

Unit code	EKAC230BR1	EKAC460BR1	EKAC690BR1	EKAC920BR1	EKAC1150BR1	EKAC1380BR1
Unit combination model	EKAC230BR1	2 × EKAC230BR1	3 × EKAC230BR1	4 × EKAC230BR1	5 × EKAC230BR1	6 × EKAC230BR1
Nominal cooling capacity	kW	68.0	136.0	204.0	272.0	340.0
Nominal heating capacity	kW	72.0	144.0	216.0	288.0	360.0
Total power of nominal cooling capacity	kW	20.2	40.4	60.6	80.8	101.0
Total power of nominal heating capacity	kW	20.0	40.0	60.0	80.0	100.0
Power supply	380V/3N~/50Hz					
Refrigerant	Type	R410A				
Throttling parts	Type	Electronic expansion valve				
Compressor	Type	Fully hermetic scroll compressor				
	Lubricant	Ester oil (POE)				
Fan	Qty	2	4	6	8	10
	Type	Axial propeller low-noise fan				
Water-side heat exchanger	Qty	2	4	6	8	10
	Type	Highly-efficient vacuum brazed plate heat exchanger				
Water flow	m ³ /h	11.7	23.4	35.1	46.8	58.5
	Water resistance	kPa				
Actual length of inlet and outlet water pipes of a single modular unit	inch	45				
Recommended length of inlet and outlet water pipes	inch	2				
Maximum input power	kW	≥ 2	≥ 3	≥ 3	≥ 4	≥ 4
Maximum operating current	A	≥ 2	≥ 3	≥ 3	≥ 4	≥ 5
Unit dimensions	L x H	29.9	59.8	89.7	119.6	149.5
	W	52.6	105.2	157.8	210.4	263.0
Net weight of the unit	kg	2012x1840				
	kg	880	2160	3440	4720	6000
Operating weight of the unit	kg	500	1000	1500	2000	2500
	kg	510	1020	1530	2040	2550
Accessory box model	EKAC-CA035					

- Note:
- Working conditions of the unit for testing the nominal cooling capacity: Outlet temperature: 7°C; water flow rate: 0.172 m³/(h·kW); outdoor ambient temperature: 35°C.
 - Working conditions of the unit for testing the nominal heating capacity: Outlet temperature: 45°C; water flow rate: 0.172 m³/(h·kW); outdoor dry/wet bulb temperature: 7°C/6°C.
 - Water resistance includes differential water pressure of the unit and that of the affiliated Y-shape filter.
 - For combined units, the manufacturer does not offer general water pipes and they must be prepared and installed on site. Diameter of the pipes should comply with design standards.
 - A modular unit can be combined by same or different modules based on actual requirements; up to 16 modules can be built into a modular unit. The parameters listed in the table above are for commonly combined units.
 - Power distribution and wiring on the unit installation site are subject to unit nameplates or Installation Manual.

Specifications of Combined Unit with a basic module of EKAC460B(R)1 (Partial Parameters)

Unit code	EKAC460B(R)1	EKAC920B(R)1	EKAC1380B(R)1	EKAC1840B(R)1	EKAC2300B(R)1	EKAC2760B(R)1
Unit combination model	EKAC460B(R)1	2 × EKAC460B(R)1	3 × EKAC460B(R)1	4 × EKAC460B(R)1	5 × EKAC460B(R)1	6 × EKAC460B(R)1
Nominal cooling capacity	kW	134.0	268.0	402.0	536.0	670.0
Nominal heating capacity	kW	(142.0)	(284.0)	(426.0)	(568.0)	(710.0)
Total power of nominal cooling capacity	kW	40.0	80.0	120.0	160.0	200.0
Total power of nominal heating capacity	kW	(41.0)	(82.0)	(123.0)	(164.0)	(205.0)
Power supply	380V/3N~/50Hz					
Refrigerant	Type	R410A				
Throttling parts	Type	Electronic expansion valve				
Compressor	Type	Fully hermetic scroll compressor				
	Lubricant	Ester oil (POE)				
Fan	Qty	2	4	6	8	10
	Type	Axial propeller low-noise fan				
Water-side heat exchanger	Qty	2	4	6	8	10
	Type	Highly-efficient vacuum brazed plate heat exchanger				
Water flow	m ³ /h	23.1	46.2	69.3	92.4	115.5
	Water resistance	kPa				
Actual length of inlet and outlet water pipes of a single modular unit	inch	48				
Recommended length of inlet and outlet water pipes	inch	2-1/2				
Maximum input power	kW	≥ 3	≥ 4	≥ 5	≥ 6	≥ 6
Maximum operating current	A	≥ 3	≥ 4	≥ 5	≥ 6	≥ 8
Unit dimensions	L x H	58.9	117.8	176.7	235.6	294.5
	W	98.1	196.2	294.3	392.4	490.5
Net weight of the unit	kg	2215x2160				
	kg	1156	3312	5468	7624	9780
Operating weight of the unit	kg	860 (855 / 890)	1720 (1710 / 1780)	2580 (2565 / 2670)	3440 (3420 / 3560)	4300 (4275 / 4450)
	kg	875 (870 / 905)	1750 (1740 / 1810)	2650 (2610 / 2715)	3500 (3480 / 4350)	4375 (4350 / 4525)
Accessory box model	EKAC-CA035					

- Note:
- Working conditions of the unit for testing the nominal cooling capacity: Outlet temperature: 7°C; water flow rate: 0.172 m³/(h·kW); outdoor ambient temperature: 35°C.
 - Working conditions of the unit for testing the nominal heating capacity: Outlet temperature: 45°C; water flow rate: 0.172 m³/(h·kW); outdoor dry/wet bulb temperature: 7°C/6°C.
 - Water resistance includes differential water pressure of the unit and that of the affiliated Y-shape filter.
 - For combined units, the manufacturer does not offer general water pipes and they must be prepared and installed on site. Diameter of the pipes should comply with design standards.
 - A modular unit can be combined by same or different modules based on actual requirements; up to 16 modules can be built into a modular unit. The parameters listed in the table above are for commonly combined units.
 - Power distribution and wiring on the unit installation site are subject to unit nameplates or Installation Manual.
 - The parameters in parentheses are the parameters of the heat pump unit.

Total Heat Recovery Unit



Domestic hot water solution

Hot water solution	Gas boiler	Solar energy	Heat pump water heater	Total heat recovery module
Reliability	The boiler system and boiler room should be added, and the heating efficiency of the boiler is low. Waste gas is produced, damaging the environment.	In cloudy and rainy weather, solar energy efficiency is low, so electric heating is necessary. This doesn't save energy, and solar energy cannot be used in all kinds of weather. Heat absorption effect is affected much by sunlight.	Water-electricity separation design to eliminate electric leakage. Safe and environmentally-friendly, with no waste gas.	Provide free hot water in summer, and heating/hot water can be switched on demand in winter. Water-electricity separation design to eliminate electric leakage. Safe and environmentally-friendly, with no waste gas.
Unit installation	The boiler system and boiler room should be added, which will increase the investment cost.	Outdoor installation occupies a large floor area, which is limited by the construction area and complex installation, increasing the investment cost.	Outdoor installation, no machine room is required.	Roof and other open areas can be used for outdoor installation. Construction investment is reduced.
	When producing hot water in winter, the heating efficiency of the boiler is low, while the energy demand is large, resulting in high operating cost. Someone is required to be on duty during operation.	There is a great demand for hot water in winter, and electric heating is necessary, which increases the operating cost.	The average EER of hot water production is about 3.0-4.0 during the whole year. The heat pump running in summer causes waste of cooling capacity, and the operating cost is higher than that of the total heat recovery mode.	When cooling in the summer, the hot water is free. Production of domestic hot water only generates operating costs in the transition season and winter.



Economical efficiency analysis

Leading energy-saving design in Europe helps save more than 60% energy.

The unit is highly efficient, environment-friendly, and energy-saving. Compared to the standard modular air-cooled heat pump unit and domestic hot water boiler, the total heat recovery modular air-cooled heat pump unit can save more than 60% energy. The following lists comparison between operating costs when temperature of 1 ton of water rises to 40°C:

Note: * indicates operating cost in summer.

Item		Natural gas boiler	Liquefied gas boiler	Piped gas boiler	Oil burning boiler	Coal burning boiler	Electric boiler	Heat pump water heater	Total heat recovery unit
Energy type		Natural gas	Liquefied gas	Gas	Diesel oil	Coal	Electricity	Air energy + Electricity	
Heat value	kCal/kg	8600	10800	4000	10200	4300	860	860	860
Energy efficiency ratio	%	80	80	80	65	60	95	400	400
Unit price	Yuan/kg	3.50	6.25	2.20	6.00	0.64	1.00	1.00	1.00
Operating cost for water heating	Yuan/day	20.4	28.9	27.5	36.2	9.9	49.0	11.6	0*

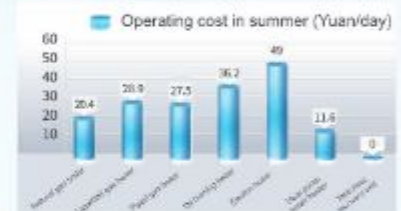

Application scenarios



Conventional Single-tank Hot Water Control System

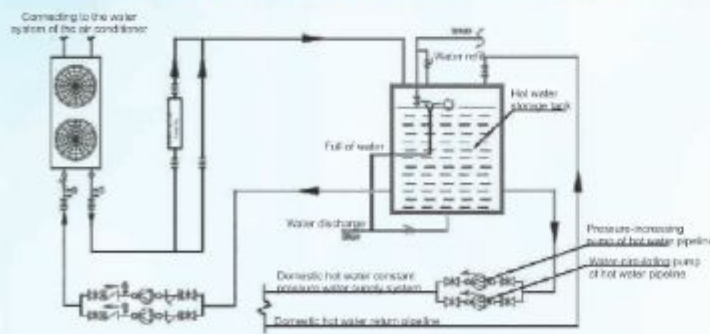

Description of traditional single tank hot water control system: (the following control points are controlled by the heat recovery host)

1. Intelligently detect the water level of the tank.
2. Intelligently detect the temperature of the tank.
3. Intelligently detect the temperature of the hot water recovery network.
4. Intelligently control startup/shutdown of the heat recovery unit.
5. Intelligently control startup/shutdown of the hot water circulating pump.
6. Intelligently control water refill of the tank.
7. Intelligently control water return of the water return pipeline.

Simple Two-tank Hot Water Control System

The simple two-tank hot water control system guarantees hot water temperature stability at the terminal during the peak period of water use. EK two-tank control system contains:



Description of the simple two-tank hot water control system: (the following control points are controlled by the heat recovery host)

1. Intelligently detect the low water level of the water tank A.
2. Intelligently detect the temperature of the tank.
3. Intelligently detect the temperature of hot water recovery pipeline network.
4. Intelligently control startup/shutdown of the heat recovery unit.
5. Intelligently control startup/shutdown of the hot water circulating pump.
6. Intelligently control water return of the water return pipeline.

One Unit for Multiple Purposes

Five Operation Modes

Five operation modes are available: cooling, cooling + heat recovery, heating, domestic hot water, and heating + domestic hot water. The unit ensures that you can meet both air-conditioning and domestic hot water needs in four seasons.

02

Heating mode

When heating is required without requiring hot water, you can select heating mode. In this case, the unit only runs in heating mode, equivalent to be a common air-cooled heat pump unit.

03

Cooling + domestic hot water mode

When both cooling and domestic hot water are required, you can select cooling + domestic hot water mode. In this case, the unit automatically starts the air-conditioning module for cooling and generating chilling water, which is used by the air conditioner. At the same time, the hot water module is started automatically to generate domestic hot water for daily use.

04

Heating + domestic hot water mode

If you require both heating and hot water, you can select the heating + domestic hot water mode. In this case, the unit adopts an air conditioner preference mode to guarantee the use of the air conditioner.

When the unit is in an idle state, the hot water module generates domestic hot water to address the needs for domestic hot water. You can also adopt the hot water preference mode according to your needs. In this case, the hot water module runs for a certain period to meet hot water needs.

01

Cooling mode

When cooling is required without requiring hot water, you can select cooling mode. In this case, the unit only runs in cooling mode, equivalent to be a common air-cooled heat pump unit.

05

Domestic hot water mode

When domestic hot water is required without requiring air conditioning, you can select domestic hot water mode. In this case, the unit provides domestic hot water only. The unit is equivalent to a common air source heat pump hot water unit.

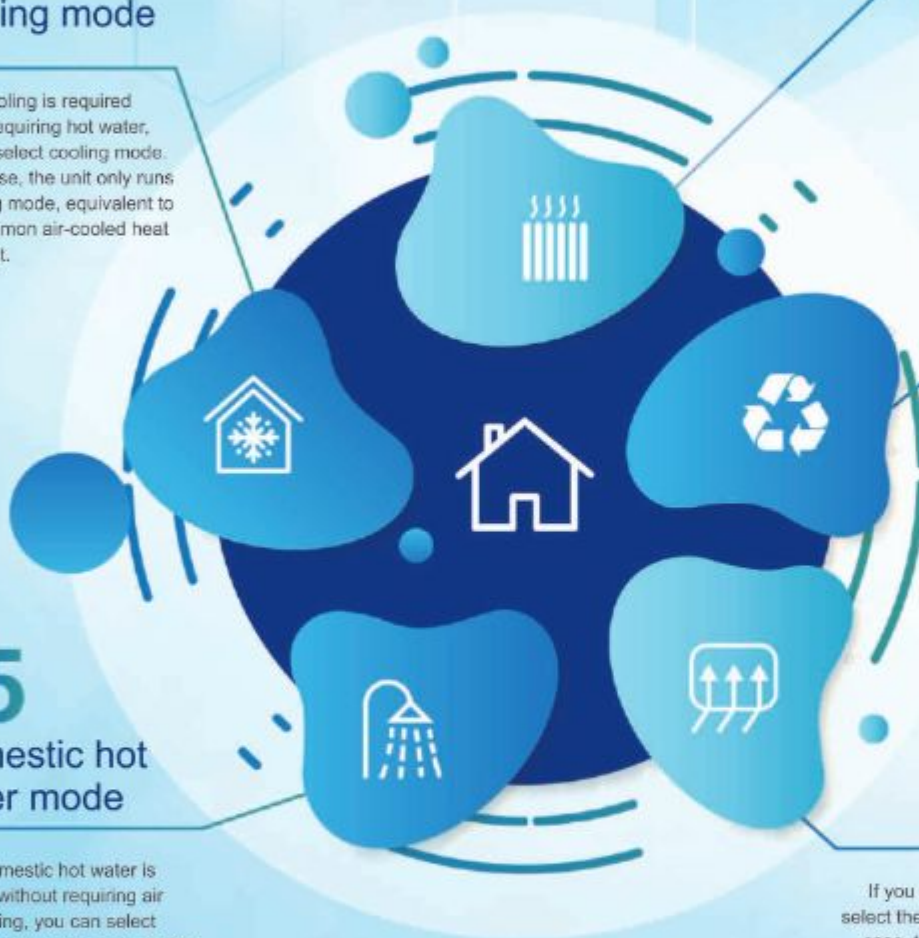

Total Heat Recovery Modular Air-cooled Chillers (Heat Pump)

Specifications of Combined Unit with a Basic Module of EKAC230BR1SR (Partial Parameters)

Combination code			EKAC230BR1SR	EKAC460BR1SR	EKAC690BR1SR	EKAC920BR1SR	EKAC1150BR1SR	EKAC1380BR1SR
Unit combination model			EKAC230BR1SR	2×EKAC230BR1SR	3×EKAC230BR1SR	4×EKAC230BR1SR	5×EKAC230BR1SR	6×EKAC230BR1SR
Air-conditioning mode	Nominal cooling capacity	kW	68.0	136.0	204.0	272.0	340.0	408.0
	Nominal heating capacity	kW	74.0	148.0	222.0	296.0	370.0	444.0
	Total power of nominal cooling capacity	kW	20.5	41.0	61.5	82.0	102.5	123.0
	Operating current under nominal cooling capacity	A	37.8	75.6	113.4	151.2	189.0	226.8
	Total power of nominal heating capacity	kW	21.0	42.0	63.0	84.0	105.0	126.0
	Operating current under nominal heating capacity	A	38.5	77.0	115.5	154.0	192.5	231.0
	Water flow under nominal cooling capacity	m ³ /h	11.7	23.4	35.1	46.8	58.5	70.2
	Water flow under nominal heating capacity	m ³ /h	12.7	25.4	38.1	50.8	63.5	76.2
	EER	W/W	3.32					
	Energy efficiency grade		2					
Domestic hot water mode	Nominal heating capacity	kW	82.0	164.0	246.0	328.0	410.0	492.0
	Power consumption under nominal heating capacity	kW	20.5	41.0	61.5	82.0	102.5	123.0
	Circulating water flow	m ³ /h	14.1	28.2	42.3	56.4	70.5	84.6
	Nominal cooling capacity	kW	64.5	129.0	193.5	258.0	322.5	387.0
Cooling + heat recovery mode	Nominal heat recovery amount	kW	84.0	168.0	252.0	336.0	420.0	504.0
	Total nominal power consumption	kW	19.5	39.0	58.5	78.0	97.5	117.0
	Water flow at the nominal heat recovery side	m ³ /h	14.1	28.2	42.3	56.4	70.5	84.6
	Water flow at the nominal cooling side	m ³ /h	11.7	23.4	35.1	46.8	58.5	70.2
	Type		Fully hermetic scroll compressor					
Compressor	Qty	Set	2	4	6	8	10	12
	Power supply		380V/3N~/50Hz					
Refrigerant	Type		R410A					
	Type		Axial propeller low-noise fan					
Fan	Qty	Set	2	4	6	8	10	12
	Heat exchanger type		Highly-efficient vacuum brazed plate heat exchanger					
Actual length of inlet and outlet water pipes of a single modular unit	Air conditioner side	inch	2					
	Hot water side	inch	2-1/2					
Recommended length of inlet and outlet water pipes	Air conditioner side	inch	≥ 2	≥ 2-1/2	≥ 3	≥ 4	≥ 4	≥ 5
	Hot water side	inch	≥ 2-1/2	≥ 3	≥ 4	≥ 4	≥ 5	≥ 6
Maximum input power	kW	30.1	60.2	90.3	120.4	150.5	180.6	
Maximum operating current	A	53.1	106.2	159.3	212.4	265.5	318.6	
Water pressure drop of the unit	Air conditioner side	kPa	45					
	Hot water side	kPa	75					
Unit dimensions	L × H	mm	2012×1840					
	W	mm	880	2160	3440	4720	6000	7280
Net weight of the unit	kg	580	1160	1740	2320	2900	3480	
Operating weight of the unit	kg	600	1200	1800	2400	3000	3600	
Accessory box model		EKAC-CA037						

Note: ◇ Air-conditioning mode:

Working conditions of the unit for testing the nominal cooling capacity: Outlet temperature: 7°C; water flow rate: 0.172 m³/(h·kW); outdoor ambient temperature: 35°C.

Testing conditions of nominal heating capacity: water outlet temperature: 45°C; water flow: 0.172 m³/(h·kW); outdoor ambient drywet bulb temperature: 7°C/6°C.

◇ Domestic hot water mode:

Nominal hot water conditions: ambient temperature: 20/15°C; water outlet temperature: 50°C; water flow: 0.172m³/(h·kW).

◇ Cooling + domestic hot water mode

Nominal test condition: hot water side: water outlet temperature: 50°C; water flow is the same as the nominal hot water flow.

Air conditioner side: water outlet temperature: 7°C; water flow is the same as the nominal cooling water flow.

◇ Water pressure drop at the unit side includes water pressure drop of the unit and water pressure drop of the accompanied Y-shape filter. Water pressure drop at the hot water side includes the water pressure drop of the unit, excluding water pressure drop of the Y-shape filter and other parts.

◇ The unit with total heat recovery function can be combined with the unit with total heat recovery function or the unit without total heat recovery function. It can be combined with 1 to 16 units.

◇ Energy Efficiency Grades comply with GB 19577-2015. The specifications and parameters in the table are subject to change without prior notice.

◇ Power distribution and wiring on the unit installation site are subject to unit nameplates or Installation Manual.

Specifications of Combined Unit with a Basic Module of EKAC460BR1SR (Partial Parameters)

Combination code		EKAC460BR1SR	EKAC920BR1SR	EKAC1380BR1SR	EKAC1840BR1SR	EKAC2300BR1SR	EKAC2760BR1SR	
Unit combination model		EKAC460BR1SR	2×EKAC460BR1SR	3×EKAC460BR1SR	4×EKAC460BR1SR	5×EKAC460BR1SR	6×EKAC460BR1SR	
Air-conditioning mode	Nominal cooling capacity	kW	130.0	260.0	390.0	520.0	650.0	780.0
	Nominal heating capacity	kW	138.0	276.0	414.0	552.0	690.0	828.0
	Total power of nominal cooling capacity	kW	40.0	80.0	120.0	160.0	200.0	240.0
	Operating current under nominal cooling capacity	A	70.8	141.6	212.4	283.2	354.0	424.8
	Total power of nominal heating capacity	kW	40.4	80.8	121.2	161.6	202.0	242.4
	Operating current under nominal heating capacity	A	71.5	143.0	214.5	286.0	357.5	429.0
	Water flow under nominal cooling capacity	m ³ /h	22.4	44.8	67.2	89.6	112.0	134.4
	Water flow under nominal heating capacity	m ³ /h	23.7	47.4	71.1	94.8	118.5	142.2
	EER	W/W	3.25					
	Energy efficiency grade		2					
Domestic hot water mode	Nominal heating capacity	kW	162.0	324.0	486.0	648.0	810.0	972.0
	Power consumption under nominal heating capacity	kW	41.5	83.0	124.5	166.0	207.5	249.0
	Circulating water flow	m ³ /h	27.9	55.8	83.7	111.6	139.5	167.4
Cooling + heat recovery mode	Nominal cooling capacity	kW	119.0	238.0	357.0	476.0	595.0	714.0
	Nominal heat recovery amount	kW	158.0	316.0	474.0	632.0	790.0	948.0
	Total nominal power consumption	kW	39.0	78.0	117.0	156.0	195.0	234.0
	Water flow of the nominal heat recovery side	m ³ /h	27.9	55.8	83.7	111.6	139.5	167.4
	Water flow at the nominal cooling side	m ³ /h	22.4	44.8	67.2	89.6	112.0	134.4
Compressor	Type		Fully hermetic scroll compressor					
	Qty	Set	2	4	6	8	10	12
Power supply			380V/3N~/50Hz					
Refrigerant	Type		R410A					
Fan	Type		Axial propeller low-noise fan					
	Qty	Set	2	4	6	8	10	12
Heat exchanger type	Air conditioning water side		Highly-efficient vacuum brazed plate heat exchanger					
	Domestic hot water side		Barrel-type heat exchanger					
Actual length of inlet and outlet water pipes of a single modular unit	Air conditioner side	inch	2-1/2					
	Hot water side	inch	3					
Recommended length of inlet and outlet water pipes	Air conditioner side	inch	≥ 3	≥ 4	≥ 5	≥ 6	≥ 6	≥ 8
	Hot water side	inch	≥ 3	≥ 5	≥ 6	≥ 6	≥ 8	≥ 8
Maximum input power		kW	56.6	113.2	169.8	226.4	283.0	339.6
Maximum operating current		A	98.4	196.8	295.2	393.6	492.0	590.4
Water pressure drop of the unit	Air conditioner side	kPa	48					
	Hot water side	kPa	76					
Unit dimensions	L×H	mm	2215×2260	2215×2260	2215×2260	2215×2260	2215×2260	2215×2260
	W	mm	1156	3312	5468	7624	9780	11936
Net weight of the unit		kg	1080	2160	3240	4320	5400	6480
Operating weight of the unit		kg	1120	2240	3360	4480	5600	6720
Accessory box model			EKAC-CA037					

Operating range

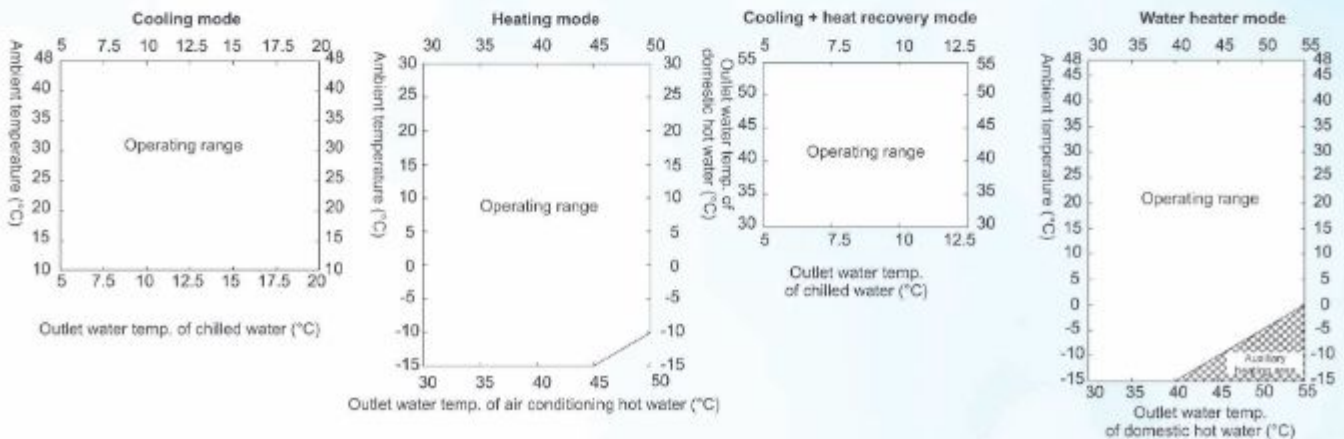

Note: The operating range is the normal range of the unit. If it is out of this range, the unit can only operate for a short time. Otherwise, the unit will generate a fault alarm.

Four-pipe Modular Unit

Constant Temperature and Humidity

Balanced Cooling and Heating

For projects with indoor temperature and humidity requirements, the four-pipe modular unit can meet the requirements of hospital clean operating rooms, heated pools, star hotels, industrial process applications, and other application scenarios. Meanwhile, it provides cooling and heating capacity, is easy to dehumidify, matches the demand for cooling and heating loads, and achieves precise temperature and humidity control with the terminal of constant temperature and humidity.



Hospital clean operating room



Hospital clean operating room

- Multi-stage air treatment & indoor constant temperature and humidity
- High cleanliness in main area & large fresh air demand



Heated pool



Heated pool

- High temperature and high humidity & cooling and dehumidifying throughout the year
- Constant water temperature & heated pool water all year round
- Large heat consumption & ventilation without circulation
- Chlorine corrosion & high requirements for corrosion protection



Star hotel



Star hotel

- Diverse functions & decentralized areas
- Building scale & large annual load change
- 24 h service & temperature and humidity demand
- 4-pipe system & free cooling/heating switching



Industrial process application



Manufacturing of electronic and optical equipment

- Meet the requirements of process temperature and humidity
- Fine machining precision
- Small temperature and humidity fluctuation range

Metrology, testing and laboratory

- Strict relative humidity requirements
- Accuracy of simultaneous temperature and humidity control



Biopharmaceutical and food manufacturing

- 40%-80% relative humidity
- Temperature should not be too high
- Avoid pollution to products



Specifications

EKAC Series

Unit code		EKAC460(R)1SR ¹⁾	EKAC920(R)1SR ¹⁾	EKAC1380(R)1SR ¹⁾	EKAC1840(R)1SR ¹⁾	EKAC2300(R)1SR ¹⁾	EKAC2760(R)1SR ¹⁾	
Unit combination code		EKAC460(R)1SR ¹⁾	2×EKAC460(R)1SR ¹⁾	3×EKAC460(R)1SR ¹⁾	4×EKAC460(R)1SR ¹⁾	5×EKAC460(R)1SR ¹⁾	6×EKAC460(R)1SR ¹⁾	
Air-conditioning mode	Cooling capacity	kW	132.0	264.0	396.0	528.0	792.0	
	Heating capacity	kW	140.0	280.0	420.0	560.0	840.0	
	Total power of cooling capacity	kW	40.0	80.0	120.0	160.0	200.0	240.0
	Total power of heating capacity	kW	38.0	76.0	114.0	152.0	190.0	228.0
	Cooling water flow	m ³ /h	22.7	45.4	68.1	90.8	113.5	136.2
	Heating water flow	m ³ /h	21.1	42.2	63.3	84.4	105.5	127.6
	EER	W/W	3.3					
	Energy efficiency grade		2					
Combined cooling and heating supply mode	Cooling capacity	kW	135.0	270.0	405.0	540.0	675.0	810.0
	Heating capacity	kW	171.0	342.0	513.0	684.0	855.0	1026.0
	Total power of capacity	kW	36.0	72.0	108.0	144.0	180.0	216.0
	Overall energy efficiency of combined cooling and heating supply	kW	8.5					
	Water flow at heating side	m ³ /h	29.4	58.8	88.2	117.6	147.0	176.4
	Water flow at cooling side	m ³ /h	23.2	46.4	69.6	92.8	116.0	139.2
Compressor	Type	Fully hermetic scroll compressor						
	Qty	Set	2	4	6	8	10	12
Refrigerant	Power supply	380V/3N~/50Hz						
	Type	R410A						
Fan	Type	Axial inverter fan						
	Qty	Set	2	4	6	8	10	12
Heat exchanger type	Cooling side	Highly-efficient vacuum brazed plate heat exchanger						
	Heating side	Barrel-type heat exchanger						
Actual length of inlet and outlet water pipes of a single modular unit	Cooling side	2-1/2						
	Heating side	3						
Recommended length of inlet and outlet water pipes	Cooling side	inch	≥3	≥4	≥5	≥6	≥6	≥8
	Heating side	inch	≥3	≥5	≥6	≥6	≥8	≥8
Water pressure drop of the unit	Cooling side	kPa	48					
	Heating side	kPa	96					
Maximum total power of capacity		kW	56.6	113.2	169.8	226.4	283	339.6
Maximum operating current		A	98.4	196.8	295.2	393.6	492	590.4
Unit dimensions	L x H	mm	2215x2260	2215x2260	2215x2260	2215x2260	2215x2260	2215x2260
	W	mm	1156	3312	5168	7024	9780	11936
Net weight of the unit		kg	1070	2140	3210	4280	5350	6420
Operating weight of the unit		kg	1110	2220	3330	4440	5550	6660
Accessory box model		EKAC-CA038						

- Note:
- Cooling design condition: Outdoor dry bulb temperature 35°C, outlet water temperature 7°C and water flow 0.172m³/(h·kW).
 - Heating design condition: Outdoor dry/wet bulb temperature 7°C/6°C, outlet water temperature 46°C and water flow 0.172 m³/(h·kW).
 - Water pressure drop at the unit chilled water side includes water pressure drop of the unit and water pressure drop of the accompanied Y-shape filter. Water pressure drop at the hot water side includes the water pressure drop of the unit, excluding water pressure drop of the Y-shape filter and other parts.

- Combined cooling and heating supply condition: The water inlet/outlet temperature of the evaporator is 12/7°C, and the water inlet/outlet temperature of the condenser is 40/45°C.
- Power distribution and wiring on the unit installation site are subject to unit nameplates or Installation Manual.
- Energy Efficiency Grades comply with GB 19577-2015. The specifications and parameters the table are subject to product change without prior notice.



Operating range

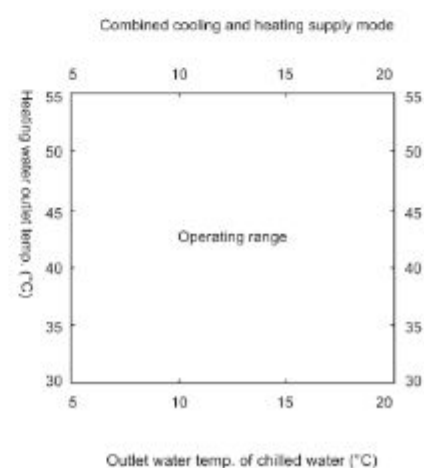
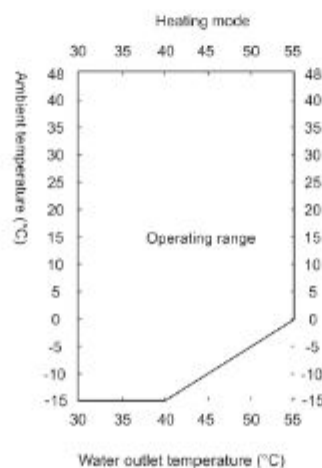
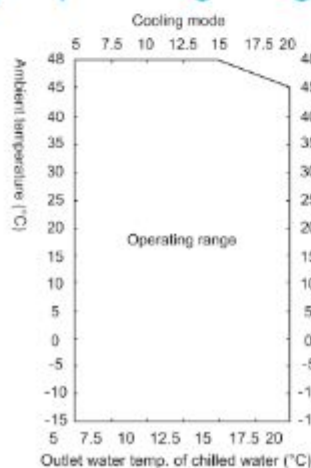

Unit Dimensions

EKAC230BR1

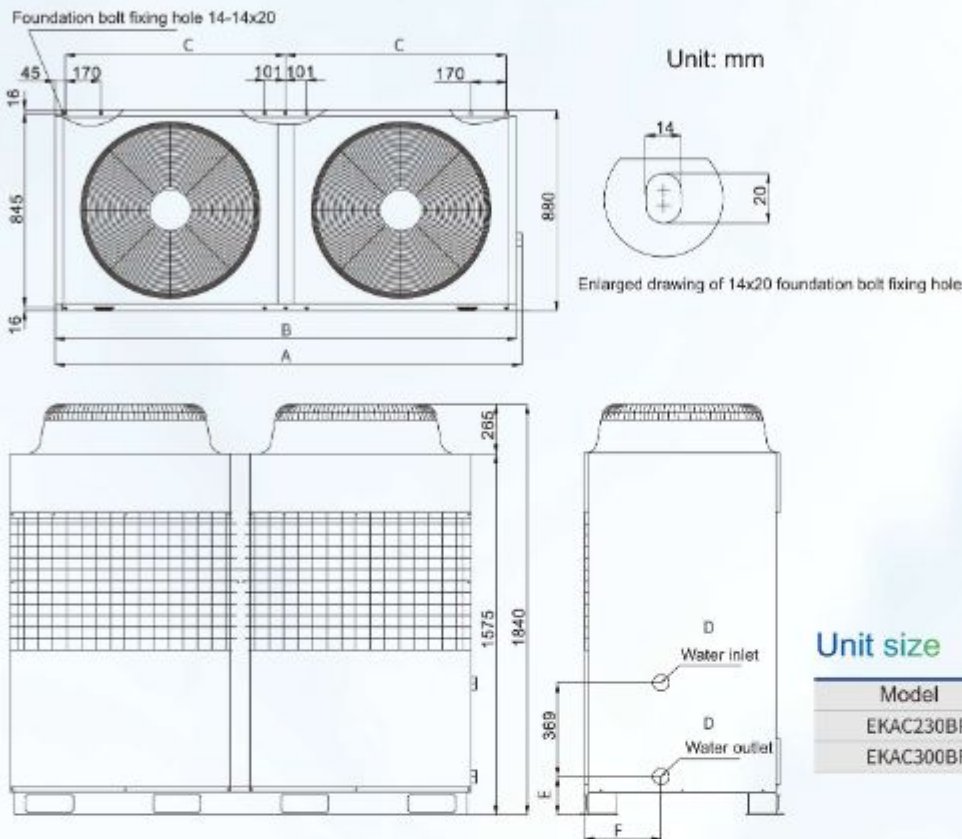

Unit size

Model	A	B	C	D	E	F
EKAC230BR1	2012	1992	950	Rc2	170	335
EKAC300BR1	2615	2590	1250	R2-1/2	175	360

EKAC460BR1

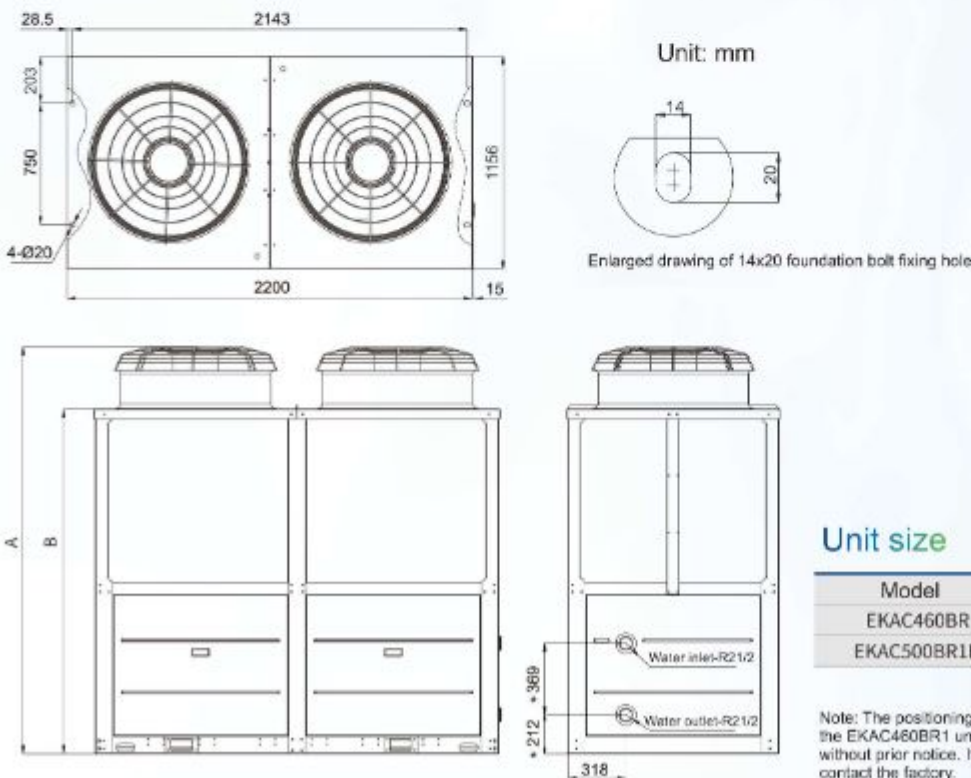

Unit size

Model	A	B
EKAC460BR1	2160	1850
EKAC500BR1LH	2260	1970

Note: The positioning dimensions (with *** symbol) of pipe connections of the EKAC460BR1 unit will change with product improvement and innovation without prior notice. If you need to confirm the positioning dimensions, contact the factory.

EKAC230BR1SR

Foundation bolt fixing hole 14-14x20

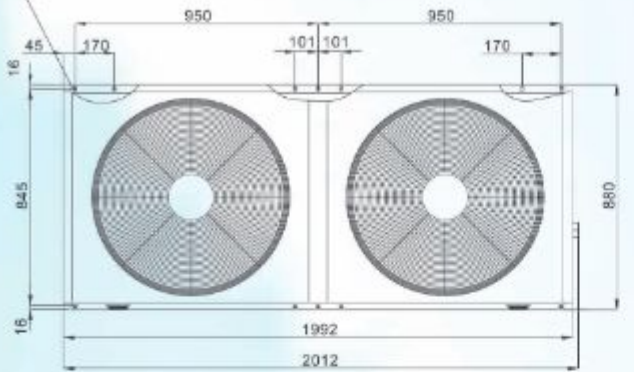

Unit: mm

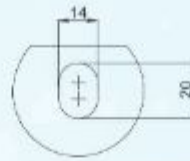

Enlarged drawing of 14x20 foundation bolt fixing hole

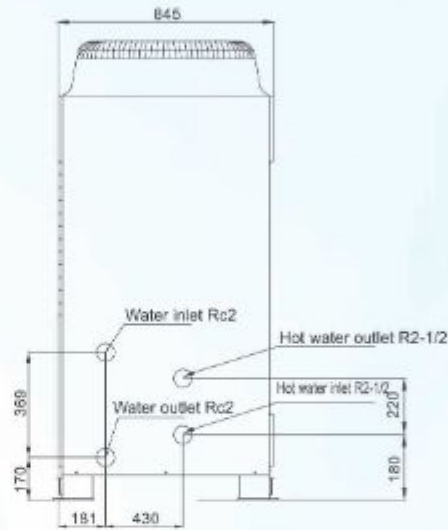
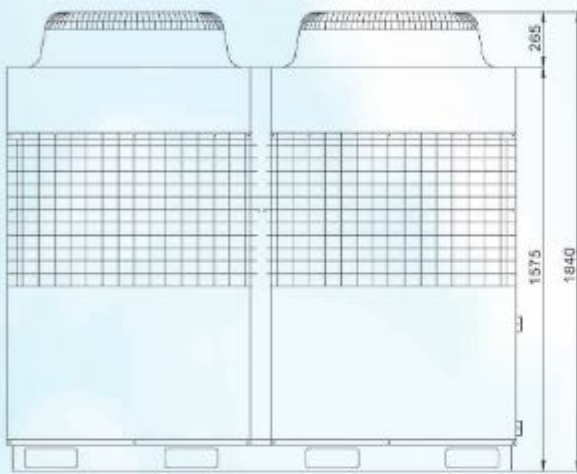

EKAC460BR1SR/EKAC460BR1SRF

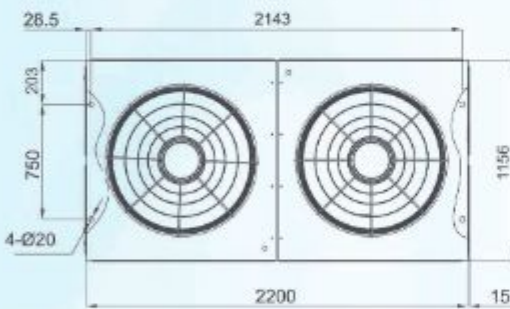

Unit: mm

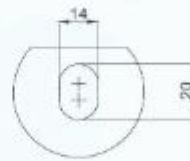

Enlarged drawing of 14x20 foundation bolt fixing hole

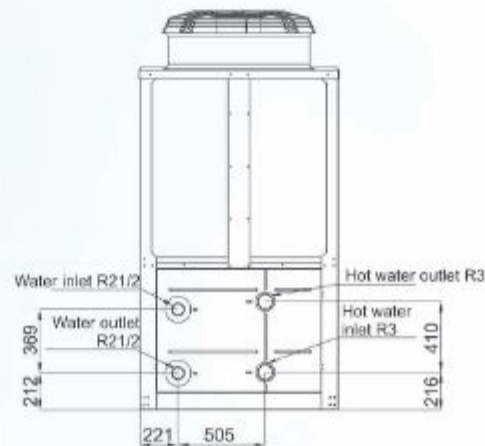
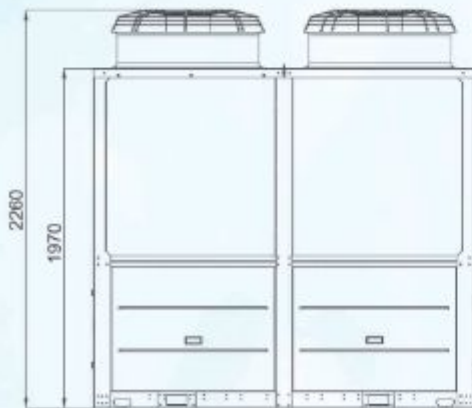

Give life to building & bring us back to nature™



Siamtemp Co.,Ltd
99/158 Moo 1, Soi Ruamsuk, Tivanont Rd, Banmai, Muang Pathumthani, Pathumthani 12000
Thailand Tel. +66(0)2501-1103-4 Fax. +66(0)2501-1103 # 2
E-mail : siamtemp@bhc.co.th / Website : <http://www.siamtemp.com> / Line@ : @siamtemp

EKAC2203-Catalog-AD

Guangdong Euroklimat Air-Conditioning & Refrigeration Co., Ltd.

Address: No.69 Qinglong Road, Huangjiang Town, Dongguan, Guangdong Province
Tel: 0769-83660888
Fax: 0769-83622528
Email: ek1963@euroklimat.com.cn
Website: www.euroklimat.com.cn

- Products in printed materials may differ from actual products. See the actual products when you purchase the products.
- The product design specification, functions, performance parameters and external structure are subject to changes without notice. For specific parameters, see the parameters on the product nameplate.
- All documents have been carefully corrected and reviewed. EUROKLIMAT assumes no responsibility for any printing errors or omissions.
- Guangdong Euroklimat Air-Conditioning & Refrigeration Co., Ltd. reserves the final right of interpretation for this document.